

APPLICATION:

PRODUCT NAME:

REEL RINSE BACK PLATE

SPEC. 29688 REV.A

JOB NAME:

SPECIAL CONFIGURATION
 CHECK BASE MODEL AND OPTIONS

QUANTITY:

ITEM NO.

MODEL:

29688

OPTIONS OR MODIFICATIONS:

SUPPLY LINES (24" OR 36") CIRCLE LENGTH
 HANDLES (CROSS OR WRIST) CIRCLE STYLE
 OTHER _____

FEATURES:

MOUNTING PLATE

- * 3/16" THICK STAINLESS STEEL
- * MOUNTS FLUSH WITH WALL
- * 8" C/C MOUNTING SCREWS WITH 1/4" DIAMETER
- * WILL ACCOMODATE ALL FISHER REELS
- * WALL BRACKET INSTALLED FOR STRENGTH

DECK CONTROL VALVE

- * 8" C/C DECK MOUNTED FAUCET
- * 1/2" MALE NPT INLETS
- * INTERNAL SPRING LOADED CHECK VALVES
- * SWIVELLING SEAT DISKS
- * HOT SIDE STEM - RIGHT HAND
- * COLD SIDE STEM - LEFT HAND
- * STAINLESS STEEL SEATS
- * STAINLESS STEEL SEAT SCREWS
- * STAINLESS STEEL HANDLE SCREWS

RISER CONTROL VALVE

- * RIGHT HAND SWIVEL STEM WITH CROSS HANDLE
- * STAINLESS STEEL SEAT
- * STAINLESS STEEL SEAT SCREW
- * STAINLESS STEEL HANDLE SCREW

VACUUM BREAKER

- * ANTI-SPILL DESIGN
- * ASSE - 1056 APPROVED

SYSTEM LIMITS

- * TEMP: 40°F TO 140°F MAX.
- * PRESSURE 200 PSI MAX. STATIC

SHIPPING WEIGHT

- * 140.0 LBS

* USE PROVIDED STUDS IN EITHER HOLE PATTERN "A" OR "B":

* HOLE PATTERN "A" CAN ACCOMODATE THE FOLLOWING REELS: **29599, 29262, 29602, 29610, 29629, 29637, 29645, 29653**

* HOLE PATTERN "B" CAN ACCOMODATE THE FOLLOWING REELS: **2980, 2985**

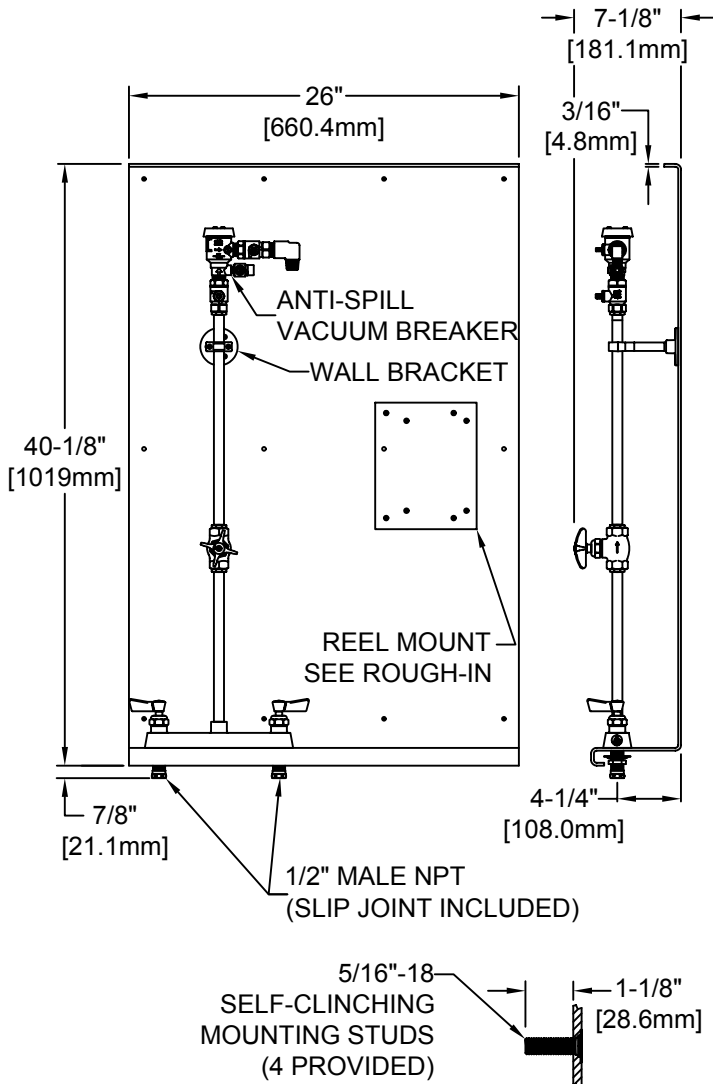

ROUGH-IN:

WALL MOUNT (REPEATING PATTERN)

REEL MOUNT**

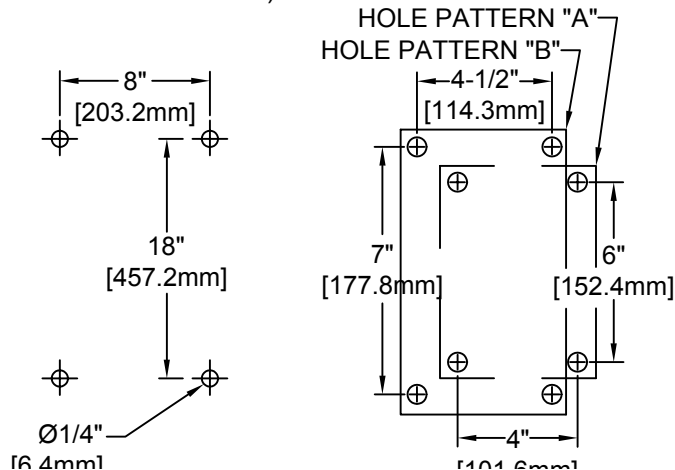

ANSI/A112.18.1M



FISHER MANUFACTURING COMPANY
TOLL FREE: 800-421-6162 - FAX: 800-832-8238
information@fisher-mfg.com - www.fisher-mfg.com